



HSE Incident  
Near-miss  
Sinkerbar dropped to rig floor

4<sup>th</sup> Nov 2009





## Sinker Bars Drop to RF During Fishing Job – 12 Aug 2009 – Roger Lewis

### The situation:

- Rigged up for through-pipe logging.
- Logging tools got stuck, washed over with DP.
- Tools unable to move free in DP.
- Reverse cut and thread.

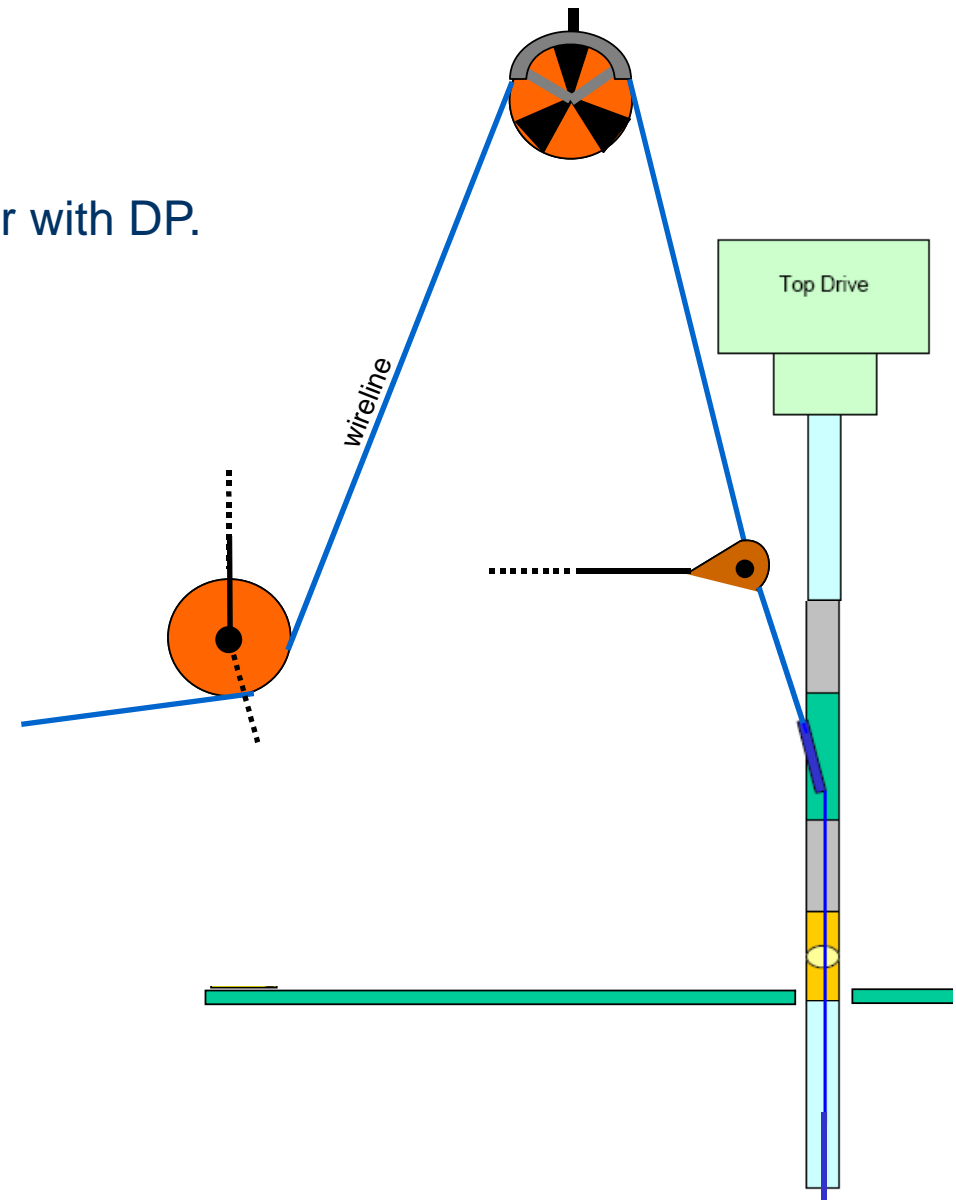
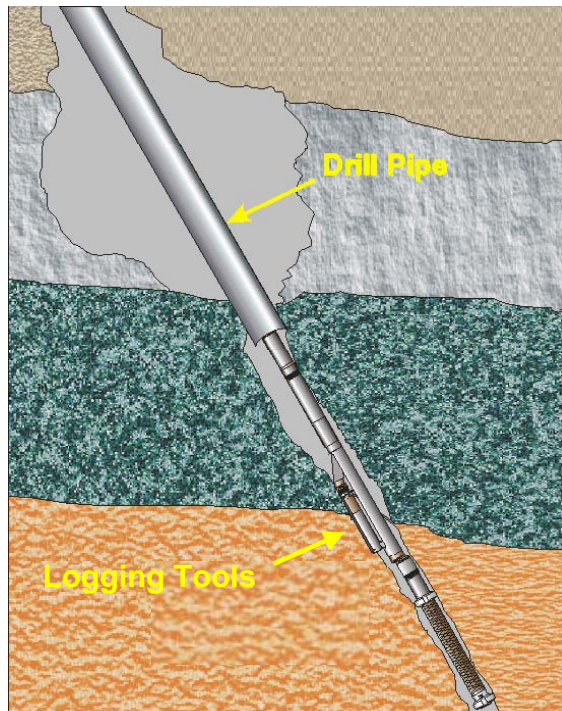



## Sinker Bars Drop to RF During Fishing Job – 12 Aug 2009 – Roger Lewis

### The situation:

- SES back at surface.
- Start reverse cut and thread
- Automated rig.
- No derrickman.
- Logging contractor's fishing kit does not have sinkerbars for reverse cut and thread.
- Contractors procedure is to pull cable without weights while disconnected stand is in the mousehole.
- This does not work on an automated rig → procedure was modified.

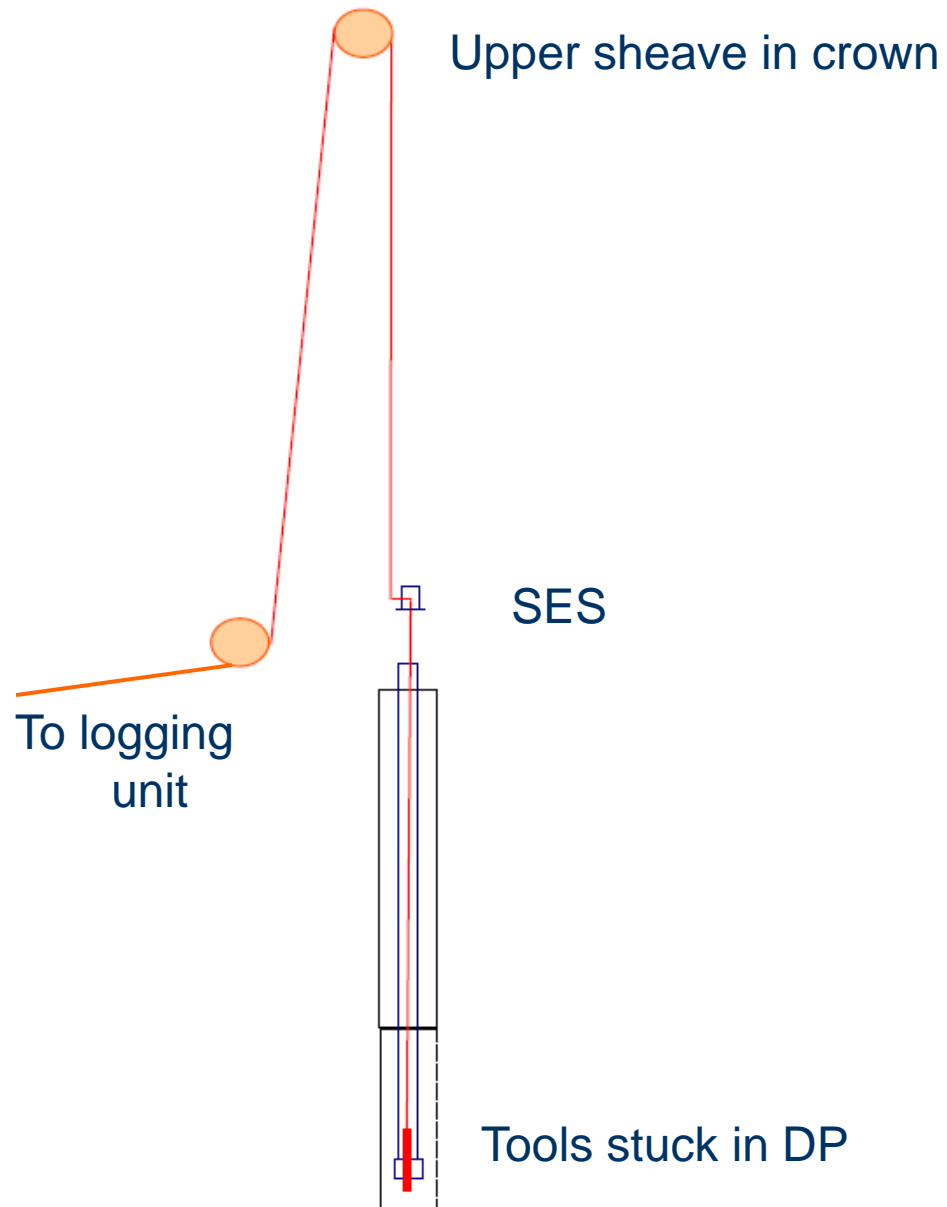



## Sinker Bars Drop to RF During Fishing Job – 12 Aug 2009 – Roger Lewis

### The situation:

- Get ready to pull the first stand.
- Procedures adapted for rig without derrick man.

Clamp wire and cut.

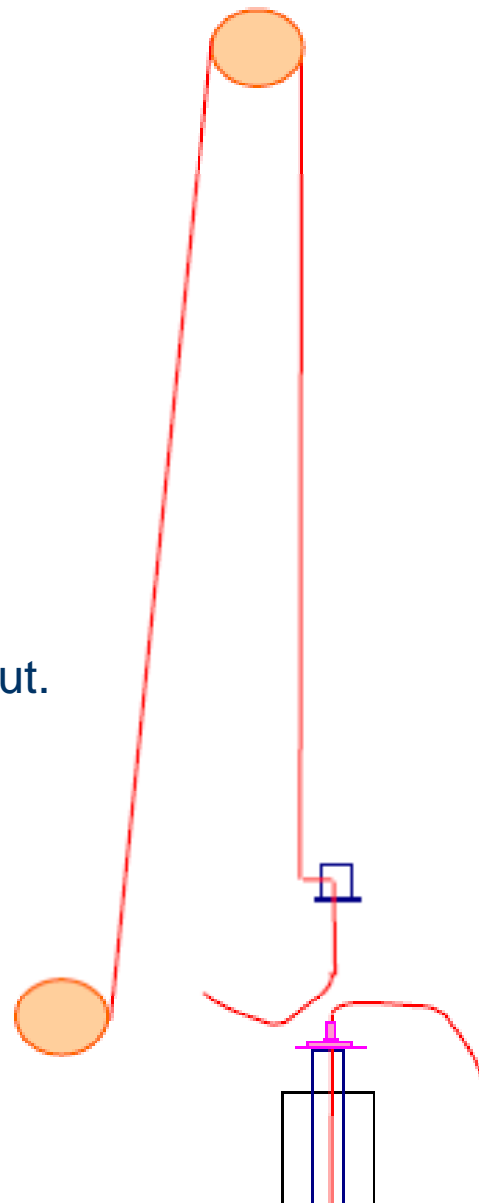

Remove SES, install sinker bar, clamp wire, pull tension, remove clamp and c-plate.

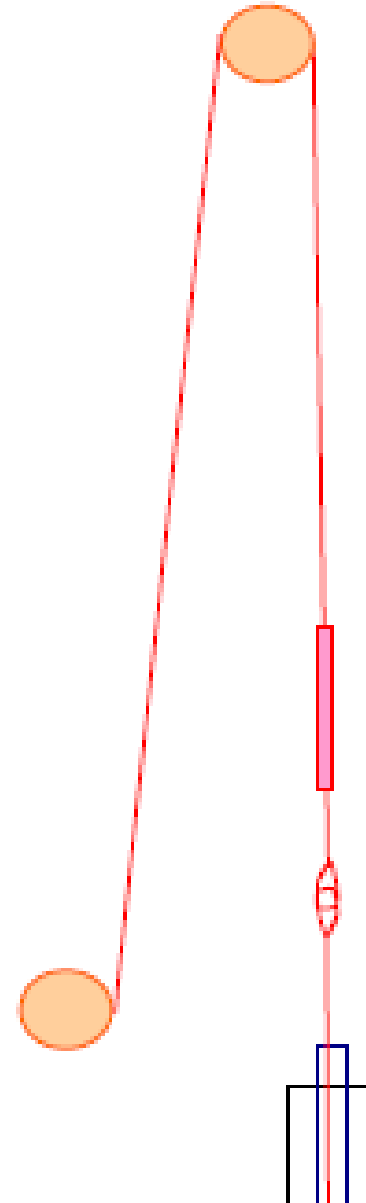



Sinker Bars Drop to RF During Fishing Job – 12 Aug 2009 – Roger Lewis

**The situation:**

- Pull the first stand.

Pull stand and wireline simultaneously.

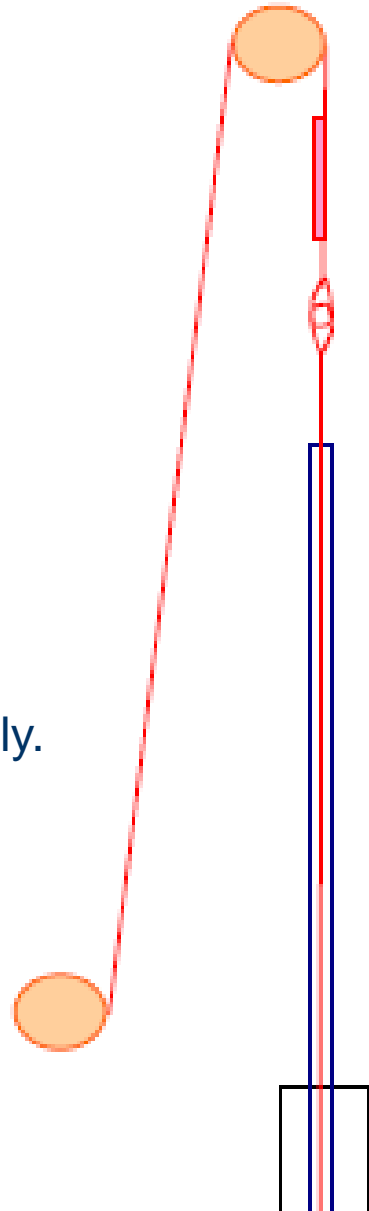

Disconnect stand, lift stand, clamp wire, cut wire.

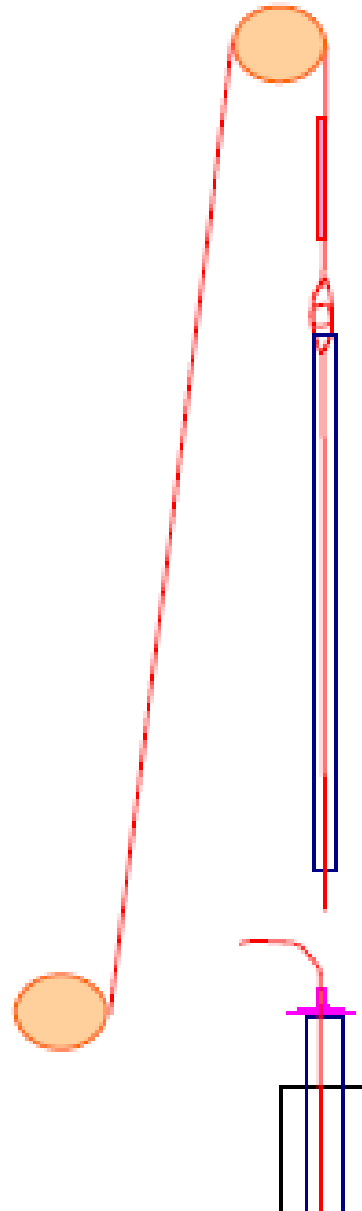



## Sinker Bars Drop to RF During Fishing Job – 12 Aug 2009 – Roger Lewis

### The situation:

- Pull the first stand.

Lower cut wire through string and coil at drill floor. Cut above the knot.

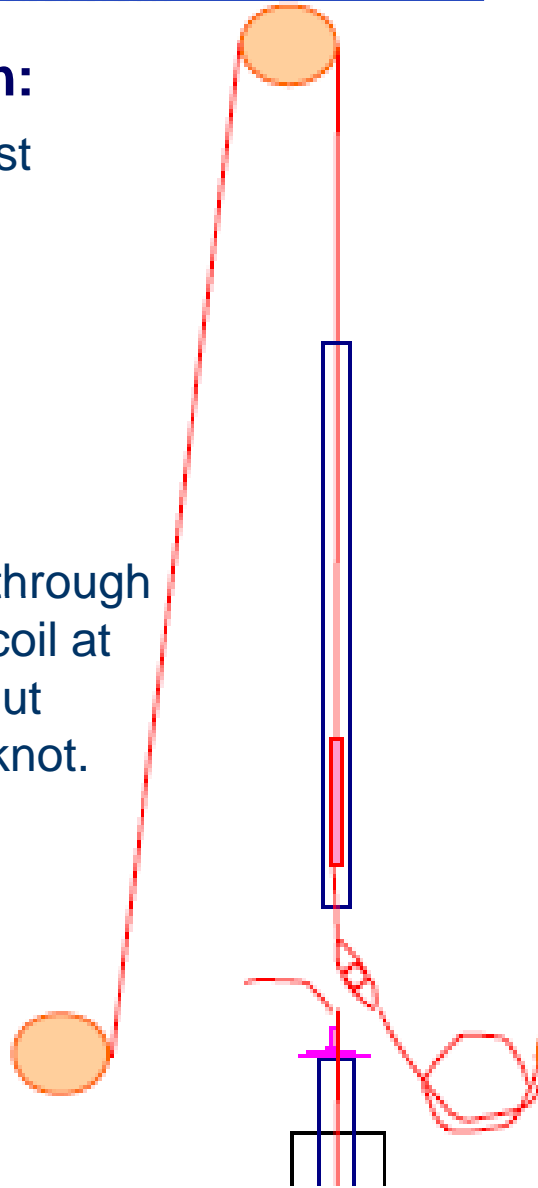

Pull the wire and sinker bar above the stand of drillpipe.

Then rack back the stand and bring the sinker bar down to the DF to start again.

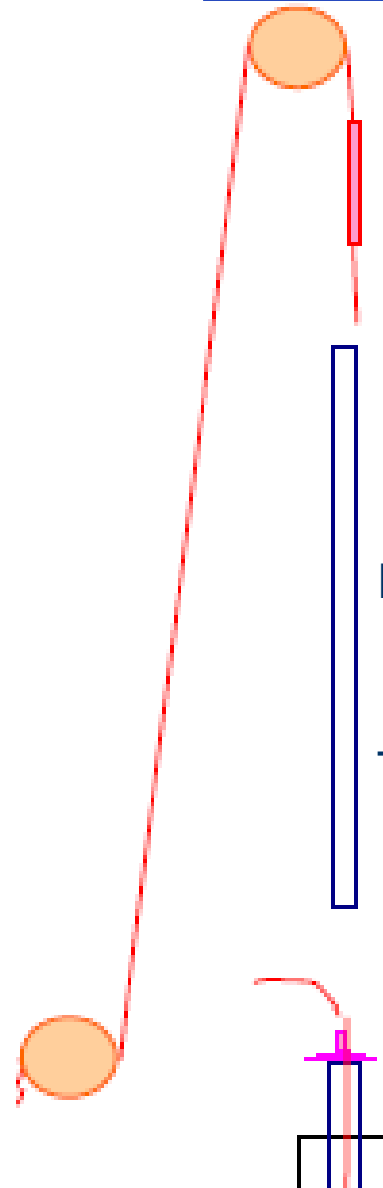



## Sinker Bars Drop to RF During Fishing Job – 12 Aug 2009 – Roger Lewis

### The situation:

- Pull the first stand.

Lower cut wire through string and coil at drill floor. Cut above the knot.

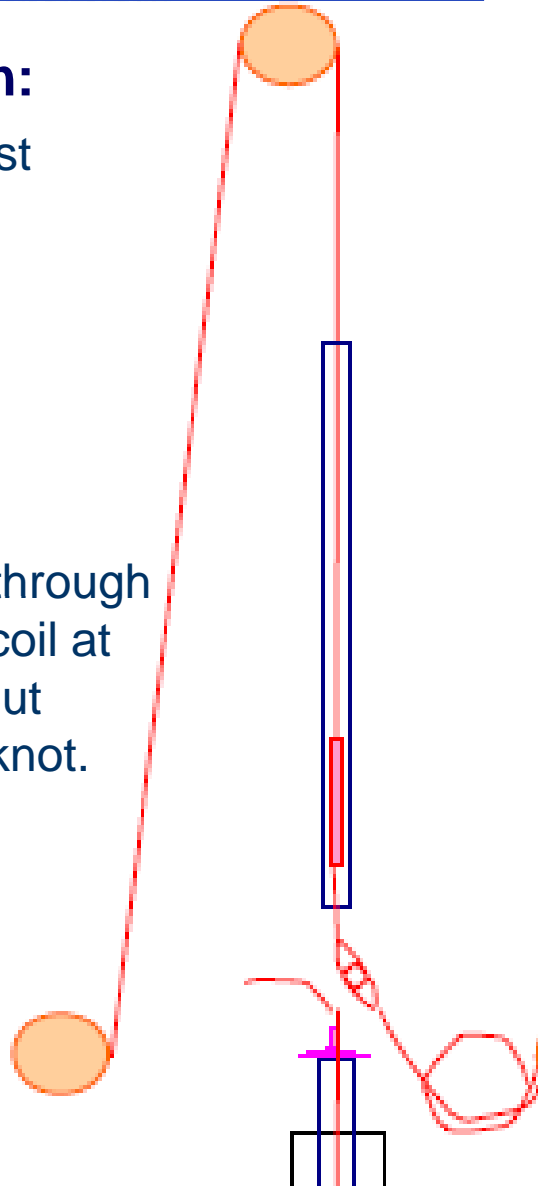

This is when the incident happened.

Pull the wire and sinker bar above the stand of drillpipe.

Then rack back the stand and bring the sinker bar down to the DF to start again.

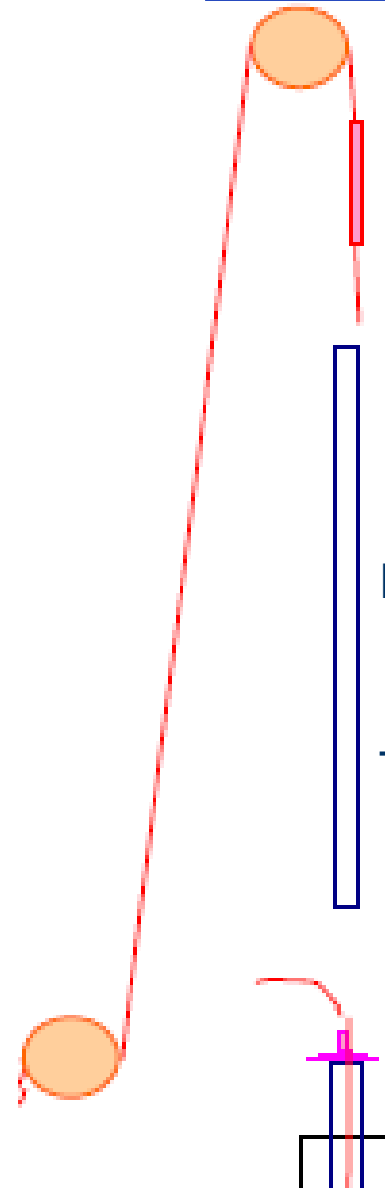



## Sinker Bars Drop to RF During Fishing Job – 12 Aug 2009 – Roger Lewis

### The incident:

- When the sinker bars cleared the top stand, they kept moving upwards, cleared the top sheave, dropping 160 ft to the drill floor.
- All staff had cleared the rig floor prior to the sinker bars hitting the rig floor.



Wireline cable /w TLC pump-down bar on DF



Unguarded crown Sheave

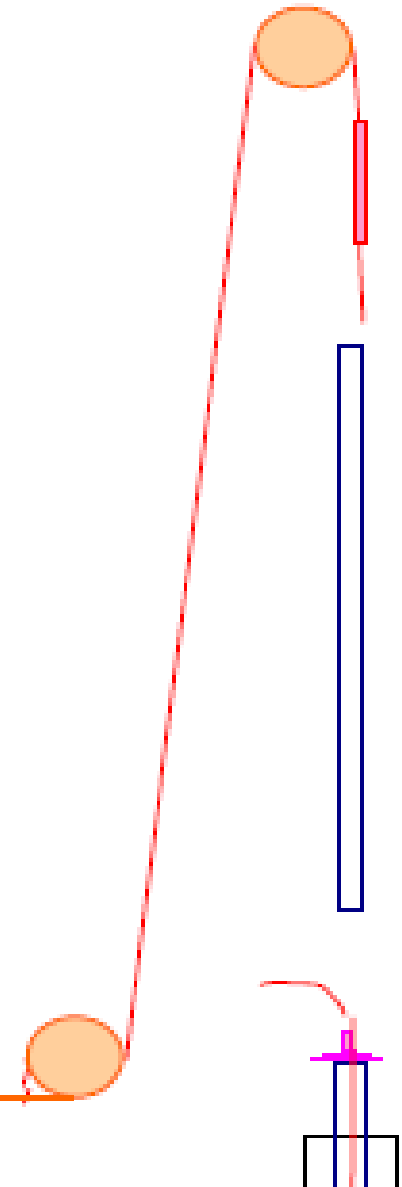



### Sinker Bars Drop to RF During Fishing Job – 12 Aug 2009 – Roger Lewis

#### Root Causes

- Fishing equipment onboard recently changed and not suitable for developed reverse cut & thread procedure: no weight bars available; used TLC weight bars instead.
- No contractor-derived fishing procedures available at the time of this operation. Those provided after incident were designed for a rig with a manual derrick, where the cut cable is pulled without weights while DP in mousehole.
- No consideration was given to do a weight calculation for both sides of the sheave (ended up 15 lbs light on DF – crown side).
- Upper sheave had no guards to prevent weight bars spooling over it.

#### Main Learning Points

- Review fishing procedures (both c&th and reverse c&th) for rigs with automated equipment.
- Developed specific procedures for fishing equipment and rig equipment.
- Rig fabricated a bar weighing 150 lbs to over-balance the newly calculated opposing wireline cable weight.
- Weight bar has no-go ring to prevent it being spooled over the upper sheave.
- Guard for upper sheave will be fabricated





## Sinker Bars Drop to RF During Fishing Job – 12 Aug 2009 – Roger Lewis



TLC pump down bars (picture 1)



TLC pump down darts (Picture2)



New Sinker Bar 150 lbs



New sinker will not fit through top sheave

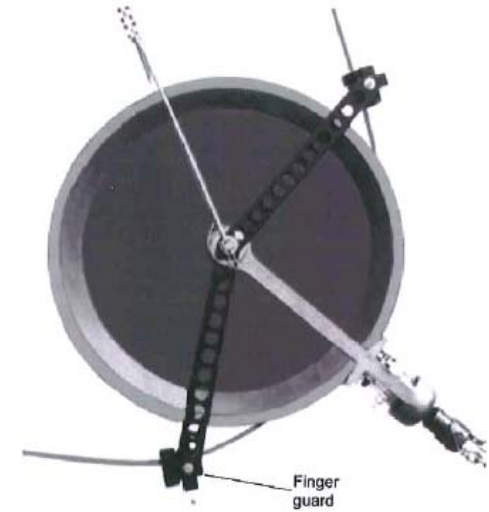

Figure 4 : Lower Sheave Wheel with Finger Guard

